

FLANGES EN 1092-1 TYPE 11B PN6 (WELDING NECK)

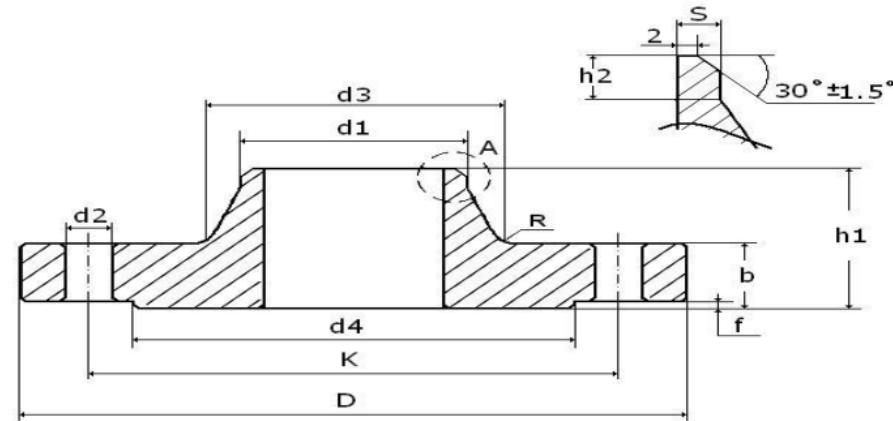

Pipe	Flange					Neck				Raised face		Screws		Weight of a flange	
	DN	d1	D	b	k	h1	d3	s	r	h2	d4	f	No.holes	Thread	d2
15	21,3	80	12	55	30	30	2,00	4	6	40	2	4	M10	11	0,408
20	26,9	90	14	65	32	38	2,30	4	6	50	2	4	M10	11	0,621
25	33,7	100	14	75	35	42	2,60	4	6	60	2	4	M10	11	0,762
32	42,4	120	14	90	35	55	2,60	6	6	70	2	4	M12	14	1,110
40	48,3	130	14	100	38	62	2,60	6	7	80	3	4	M12	14	1,260
50	60,3	140	14	110	38	74	2,90	6	8	90	3	4	M12	14	1,430
65	76,1	160	14	130	38	88	2,90	6	9	110	3	4	M12	14	1,770
80	88,9	190	16	150	42	102	3,20	8	10	128	3	4	M16	18	2,880
100	114,3	210	16	170	45	130	3,60	8	10	148	3	4	M16	18	3,410
125	139,7	240	18	200	48	155	4,00	8	10	178	3	8	M16	18	4,650
150	168,3	265	18	225	48	184	4,50	10	12	202	3	8	M16	18	5,500
200	219,1	320	20	280	55	236	6,30	10	15	258	3	8	M16	18	8,600

EN 1092-1
TYPE 11B PN6