

## FLANGES EN 1092-1 TYPE 11B PN16 (WELDING NECK)

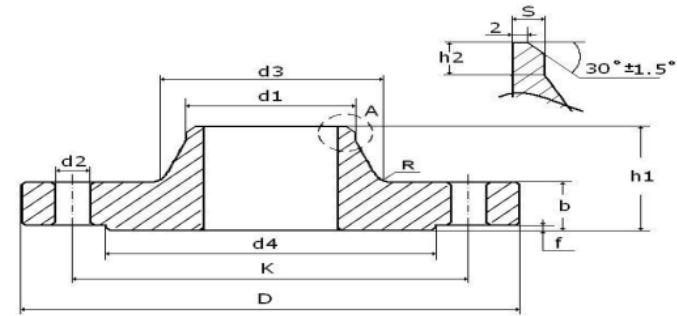

Pipe		Flange				Neck				Raised face		Screws			Weight of a flange
DN	d1	D	b	k	h1	d3	s	r	h2	d4	f	No.holes	Thread	d2	Kg
15	21,3	95	16	65	38	32	2,00	4	6	45	2	4	M12	14	0,768
20	26,9	105	18	75	40	40	2,30	4	6	58	2	4	M12	14	1,090
25	33,7	115	18	85	40	46	2,60	4	6	68	2	4	M12	14	1,300
32	42,4	140	18	100	42	56	2,60	6	6	78	2	4	M16	18	1,910
40	48,3	150	18	110	45	64	2,60	6	7	88	3	4	M16	18	2,150
50	60,3	165	18	125	45	74	2,90	6	8	102	3	4	M16	18	2,530
65	76,1	185	18	145	45	92	2,90	6	10	122	3	4	M16	18	3,120
65	76,1	185	18	145	45	92	2,90	6	10	122	3	8	M16	18	3,030
80	88,9	200	20	160	50	105	3,20	6	10	138	3	8	M16	18	3,920
100	114,3	220	20	180	52	131	3,60	8	12	158	3	8	M16	18	4,620
125	139,7	250	22	210	55	156	4,00	8	12	188	3	8	M16	18	6,300
150	168,3	285	22	240	55	184	4,50	10	12	212	3	8	M20	22	7,810
200	219,1	340	24	295	62	235	6,30	10	16	268	3	12	M20	22	11,500
250	273,0	405	26	355	70	292	6,30	12	16	320	3	12	M24	26	16,700
300	323,9	460	28	410	78	344	7,10	12	16	378	4	12	M24	26	22,100
350	355,6	520	30	470	82	390	8,00	12	16	438	4	16	M24	26	32,800
400	406,4	580	32	525	85	445	8,00	12	16	490	4	16	M27	30	41,100
450	457,0	640	34	585	83	490	8,80	12	16	550	4	20	M27	30	48,500
500	508,0	715,0	36	650	84	548	8,80	12	16	610	4	20	M30	33	63,400
600	610,0	840,0	40	770	88	670	11,00	12	18	725	5	20	M33	36	96,000

EN 1092-1  
TYPE 11B PN16