

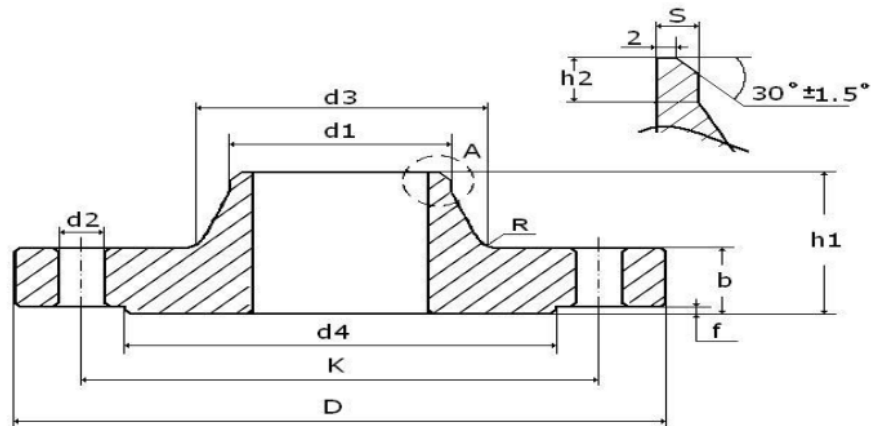

EN 1092-1
TYPE 11B PN10

FLANGES EN 1092-1 TYPE 11B PN10 (WELDING NECK)



Pipe		Flange				Neck				Raised face		Screws			Weight of a flange
DN	d1	D	b	k	h1	d3	s	r	h2	d4	f	No.holes	Thread	d2	Kg
200	219,1	340	24	295	62	234	6,30	10	16	268	3	8	M20	22	11,600
250	273,0	395	26	350	68	292	6,30	12	16	320	3	12	M20	22	15,800
300	323,9	445	26	400	68	342	7,10	12	16	370	4	12	M20	22	18,300
350	355,6	505	26	460	68	385	7,10	12	16	430	4	16	M20	22	25,300
400	406,4	565	26	515	72	440	7,10	12	16	482	4	16	M24	26	30,600
450	457,0	615	28	565	72	488	7,10	12	16	532	4	20	M24	26	35,100
500	508,0	670	28	620	75	542	7,10	12	16	585	4	20	M24	26	40,500
600	610,0	780	30	725	82	642	8,00	12	18	685	5	20	M27	30	52,900